

Performance

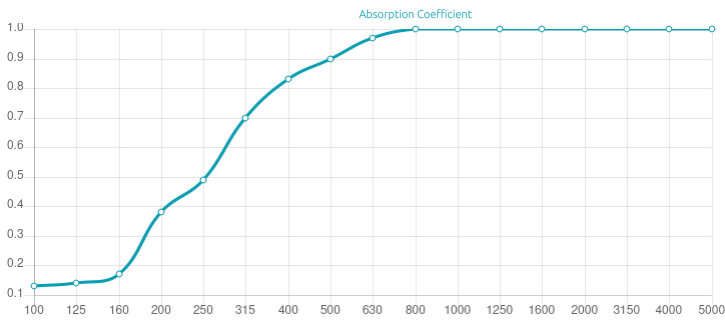

Technical Information

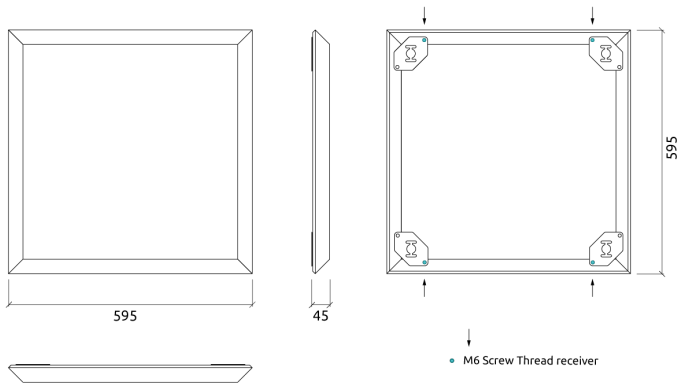

Features

Absorption Range: 315 Hz to 4000 Hz
Acoustic Class: B | (aw) = 0,80

This product is available in the following Fire Rates:
FG | Furniture Grade
FR | Fire Rated

PRODUCT COMPOSITION:

- Troy Med | - Fire Retardant Acoustic Antimicrobial Fabric | Antimicrobial & Cleanable Fabric Finish (FG)
- Fire Retardant Acoustic Antimicrobial Fabric | Antimicrobial & Cleanable Fabric Finish
- Marine-grade Plywood Structural Frame
- Sound PET acoustic core - Euro Class B

- Troy Med | - Fire Retardant Acoustic Antimicrobial Fabric | Antimicrobial & Cleanable Fabric Finish (FR)
- Fire Retardant Acoustic Antimicrobial Fabric | Antimicrobial & Cleanable Fabric Finish
- Fire Retardant HMDF Structural Frame
- Sound PET acoustic core - Euro Class B

This panel is installed with an integrated fixing system

Dimensions:

- FG - TB | 595x595x45mm | 2.47 Kg
- FR - TB | 595x595x45mm | 2.47 Kg

Noise in healthcare facilities is a well know problem with serious consequences. Acoustic levels in today's hospitals are the highest ever documented and have a tremendous impact on the privacy, comfort and stress levels of patients and staff. Even in well-being spaces, such as gyms, pools or spas; acoustic comfort plays a huge role in how beneficial and enjoyable our experience is.

Artnovion's pioneer MedLine offers high-quality acoustic solutions tailored to the strict requirements of these spaces. From panels made from hospital-grade anti-bacterial coatings, to extremely hard-wearing, washable, anti-odour finishes – the Medline caters to a wide market, solving acoustic issues in environments that - up to now – have been impossible to address.

Troy is an efficient fabric absorber panel, with high-performance levels reaching down to the 315 Hz region. Troy's outer frame encloses all sides of the panel, that also has a simple, integrated fixing system, that installs the panel flush to the surface, which make this panel a perfect choice for ceiling and wall applications.

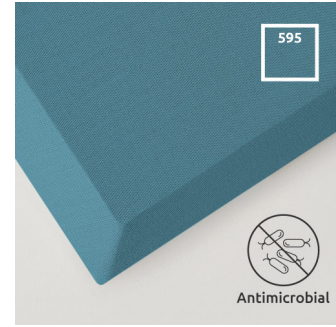

Product finishes

(FG - TB) Antimicrobial Fabric Finishes



FG | (TB139) Daisy



FG | (TB140) Sunflower



FG | (TB141) Midnight Blue



FG | (TB142) Deep Blue



FG | (TB143) Mint



FG | (TB145) Chamomile



FG | (TB146) Cool Grey



FG | (TB147) Still Grey

(FR - TB) Antimicrobial Fabric Finishes



FR | (TB139) Daisy



FR | (TB140) Sunflower



FR | (TB141) Midnight Blue



FR | (TB142) Deep Blue



FR | (TB143) Mint



FR | (TB145) Chamomile



FR | (TB146) Cool Grey



FR | (TB147) Still Grey

Purpose

- First reflection Control
- RT reduction
- Flutter echo control
- Reducing excessive reverberation
- Improving speech intelligibility

Recommended for

- Meeting Rooms
- Auditoriums
- Food Courts
- Public Corridors
- Receptions
- Waiting Rooms